

Garlock Butterfly Valves

Trusted throughout chemical, petrochemical and many other industries



Table of contents

GARLOCK BUTTERFLY VALVES	
Overview	3
The correct type of lining	4
Head flange, body, flange types design and shaft sealing	5
Materials	6
Production	7
Test engineering	8
Standards	9
The correct material choice for your application	10
GAR-SEAL, SAFETY-SEAL AND MOBILE-SEAL	
Applications GAR-SEAL	11
Applications SAFETY-SEAL	12
Applications MOBILE-SEAL	13
Materials	14
Dimensions, Wafer	15
Dimensions, Lug	16
Dimensions, Wafer tank truck	17
STERILE-SEAL	
Applications	18
No survival for bacteria	19
2-chamber-system guarantees production safety	20
Dimensions	21
Dimensions, Wafer	22
Dimensions, Lug	23
Explosion view	24
ANCILLARY COMPONENTS	
Mounting flange	25
Hand-Lever	26
Gear Operator	27
TECHNICAL DETAILS	
Technical Data	28
Special Vacuum Design	30

Garlock Butterfly Valves

For corrosive and abrasive media

The economic advantages of reduced maintenance, smooth operation and exceptional service life are proven over and over again. Garlock valves set the standards in TA-Luft compliance. The reliability of Garlock butterfly valves is not only appreciated and well known at our customers but also certified with SIL 3 according to EN 61508.

GAR-SEAL

GAR-SEAL valves are used extensively where corrosive, abrasive and toxic media needs to be reliably controlled. They are typically used for accurate control, throttling and shut-off duties in the chemical, petrochemical, chlorine, paper, electro-plating and many other industries. GAR-SEAL butterfly valves offer reduced maintenance requirements and increased operational reliability.



MOBILE-SEAL

MOBILE-SEAL valves are used on road tanker vehicles, railway wagons, silos and other transportation and storage containers where high chemical resistance, reliability and special safety requirements are essential. MOBILE-SEAL is EN 14432 approved.



SAFETY-SEAL

SAFETY-SEAL valves are used in applications where corrosive, abrasive and toxic media needs to be handled and electrostatic charges must be avoided at the same time.



STERILE-SEAL

STERILE-SEAL valves are used on duties where sterile processes need to be maintained in the pharmaceutical and food industries without unnecessary and costly overhauls and replacement. The special characteristic of this valve is its external sterilization capability. The design is such that the critical „dead“ areas of the valve, as well as the disc, body liner and seals, can be sterilized with steam without coming in contact with the process medium.



The correct type of lining

Operating temperature:
 -40 °C up to +200 °C
 -40 °F up to +392 °F



PTFE
 Void-free body liner and disc isostatic moulded from virgin PTFE. High material density > 2.16 g/cm³. Guaranteed lining thickness of at least 3 mm plus high crystallinity. FDA conform.

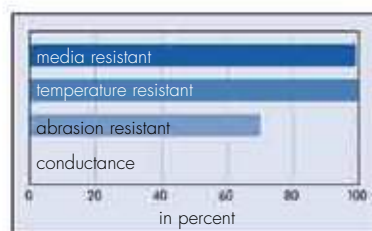

Operating temperature:
 -40 °C up to +200 °C
 -40 °F up to +392 °F



Abrasive PTFE
 Is the chemical resistance of PTFE needed and the media also provided with abrasive characteristics, the use of PTFE anti-abrasive is recommended. This special PTFE compound is essentially resistant to mechanical wear with almost the same chemical resistance as virgin PTFE.

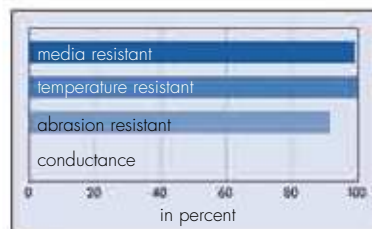

Operating temperature:
 -40 °C up to +200 °C
 -40 °F up to +392 °F



Antistatic PTFE
 For explosive environments and medias this electrostatically conductive lining is available. The service life is comparable to the values for valves lined with PTFE. The material is FDA conform. TÜV approval (TÜV 941 F 416 601). Surface resistance ≤ 10⁶ Ω. Volume resistance ≤ 10⁶ Ω cm.

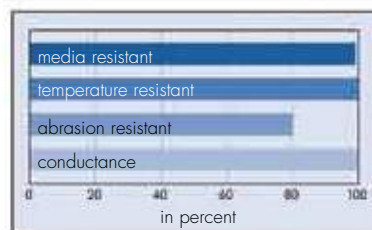

Operating temperature:
 -40 °C up to + 85 °C
 -40 °F up to + 185 °F



UHMWPE
 Used in extremely abrasive media applications while offering excellent chemical resistance. Garlock offers a complete, ultra high molecular weight PE (UHMWPE) liner and encapsulated disc.

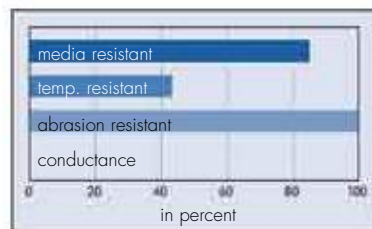

With reliability at the forefront



Section through the head flange:

The shaft is sealed against atmospheric pollution and corrosion by two o-rings. TA-Luft compliant sealing is standard. If control connection is needed, it can be integrated to observe the shaft tightness.

Body

According to Pressure Equipment Directive the bodies of Garlock valves are approved by TÜV Rheinland according to DIN 3840 and EN 12516.



Flange types

The Gar-Seal valves are available in Wafer and Lug type.

Design

The two piece design of shaft and disc allows an easy change of disc and liner. To your convenience disc and liner can be delivered as a pre assembled set.

Shaft sealing

The fully reliable shaft sealing system with the Garlock seal rings guarantees tightness over a long period. The shaft sealing system consists of two barriers. The first is an area where disc and liner are pressed together. The second barrier is the Garlock seal ring which includes a PTFE-ring energized by two o-rings. The long extensively approved system is completely maintenance free. The structure allows easy maintenance and replacement of disc and liner on site without special tools. The shaft sealing is certified according to „TA-Luft“ and exceeds the requirements.



Quality assurance

Garlock valves set the standard in high quality. To ensure this and guarantee a long reliable life time the Garlock quality management system is certified according to ISO 9001 and PED 97/23/EC Module H1. Each valve is extensively tested according to EN 12266 before leaving our factory. To ensure absolute traceability of the materials each valve is tagged with a serial number on a stainless steel tag. Based on the serial number, material certificates for body parts, PTFE/UHMWPE resins, shaft and steel disc can be provided. This high standard guarantees absolute quality, control and transparency.

Certificates and approvals

- » DIN EN ISO 9001:2008
- » PED 97/23/EC Module H1
- » Material certificate EN 10204 - 3.1
- » Testing according to EN 12266
- » 100% spark test of all PTFE and UHMWPE parts

Materials



Housing materials

It is standard practice that the housings of the Garlock valves and fittings are manufactured from high-quality ductile cast iron (EN-JS 1049). Depending on the intended use, however, other materials, such as cast steel (1.0619) and stainless steel (1.4581) are also available. All housings are manufactured and inspected in accordance with the specification of the pressure equipment directive.



Liner

Depending on the intended use, a large selection of lining materials is available. To provide reliable seals, PTFE is available in several versions as well as UHMWPE. All lining materials are manufactured by specialists and inspected comprehensively. Your contact for Garlock products will be happy to assist you in selecting the suitable material.

Elastomers

- » Silicon (standard)
- » Viton
- » EPDM
- » Neoprene



Disc

The disc is also available in different materials depending on application. Along side plastics such as PTFE and UHMWPE, stainless steel, Hastelloy Grade C or Titan are an option. All discs are manufactured by specialists and inspected comprehensively.

Marking

Each valve is tagged with a stainless steel plate. All information such as dimension, serial number, type, materials, operating pressure and temperature, flange connection and certification are engraved.

Production



All processes have been defined through our ISO 9001 quality assurance system. The system is regularly reviewed and constantly developed. Quality, service and flexibility of the highest order are standard requirements we impose on ourselves and all our suppliers.

Approvals

- » PED 97/23/EC
- » TA Luft / VDI 2440
- » EN 61508 - SIL 3
- » TR-Certificate
- » Chlorine Approval (RUS)
- » EN 14432 (Mobile Seal)
- » EN 15848-1



Due to our production facility in Germany and stock all over the world, we are in a position to react to your requirements in a very short time, worldwide.



We manufacture each valve according to customer´s requirements. In doing so, we carry out all necessary configurations as per your specifications.

Custom-tailored service:

We are happy to help you to find the most suitable product for your particular application. In this respect, we have a high number of standard products available to you. In addition, project planning and design of custom-made solutions for our customers is one of our strengths, where we draw on decades of experience as a global manufacturer of seals and valves.

We offer professional consulting and project planning that is geared towards your requirements.

Your benefit from our individual on-site support services which are specifically tailored to meet your company´s needs. We conduct training seminars, help optimize inventory, reduce emissions, ensure functionality and prevent costly downtime. Our experienced employees will be happy to assist you at any time.

Test engineering

Testing

All our valves are tested according to EN 12266-1 before they are sent out to you. Standard tests are body strength (P10), body tightness (P11) and seat tightness (P12). Also a functional test is performed.



Dimensions of liner thickness

On all PTFE parts, the liner thickness is also checked in accordance with specific measuring methods. The test ensures that the required thicknesses are adhered reliably for all parts. This measure is indicative of the special attention paid to quality requirements of GAR-SEAL valves.

This guarantees a long and reliable lifetime of PTFE and UHMWPE parts during operation.



To ensure constant high quality valves all components are subjected to stringent testing running in parallel with all stages of production.



Vacuum

GAR-SEAL valves are suitable for use in a vacuum. For use in practical applications at elevated temperatures and simultaneously high vacuums there are special vacuum linings with increased wall thickness available.



Conductivity

The PTFE body lining and the lining of the disc of the SAFETY-Seal (conductive version) are all checked for the required conductivity.

These measurements are carried out with the resistivity measurement device in accordance with the specific guidelines. This ensures that electrostatic loads are safely discharged during operations.

Standards

Garlock Butterfly Valves provide improved reliability

Face-to-face dimensions

- » DIN EN 558-1 GR 20
- » ISO 5752 Table 5 short
- » ASME B16.10
(2" to 12" Table Narrow
14" to 24" Table Wide)
- » MSS-SP 67
(2" to 12" Table Narrow
14" to 24" Table Wide)
- » API 609
(2" to 12" Category A
14" to 24" Category B)

Adapter flange

- » DIN/ ISO 5211
- » NF E 29-402

Body types

- » Wafer
- » Lug
- » With long neck for insulation in accordance with HeizAnl.V (German Heating Installations Ordinance)

Body strength

- » DIN EN 12516 T2 (DIN 3840), tested within the scope certification according to PED 97/23/EC Module H1

Body materials

- » Spheroidal graphite cast iron (EN-JS1049, 0.7043)
- » Cast steel (GS-C 25, 1.0619)
- » Stainless steel casting (G-X5CrNiMoNb 18 10, 1.4581)

Flange connection

- » EN 1092 PN 10/16 (Design A/B)
- » ASME B16.5 Class 150 lbs (Design RF, FF)

Testing

- » EN 12266 P10
- » EN 12266 P11
- » EN 12266 P12 Leak rate A

PTFE lining

- » void-free
- » isostatic pressed
- » high density (min. 2.16 g/cm³)
- » lining thickness min. 3 mm
- » vacuum lining up to 10 mm available

Vacuum tightness

- » $q^{He}_{max} < 10^{-6} \text{ mbar } 1 \cdot \text{s}^{-1}$

Identification

- » DIN EN 19
- » AD 2000 data sheet A4

Valve disc alignment

- » Centrally, i.e. energy-saving

Characteristic

- » Linear

The correct material choice for your application

Valve Material			Design Type								
1 Valve Body		2 Body Liner		3 Disc		4 Specific Design Body Liner		5 Valve Type		6 Body Type	
Code	Material	Code	Material	Code	Material	Code	Material	Code	Material	Code	Material
1	EN-JS 1049 (0.7043)	1	PTFE**	1	PTFE**	A	antistatic (SAFETY-SEAL)	V	Vacuum	W	WAFER Ring Body
2	GS-C 25 (1.0619)	2	UHMWPE***	2	UHMWPE***	C	abrasive service	SV	Special vacuum	L	LUG Flange-On-Body
3	Stainless steel (1.4581)			3	Stainless steel (1.4581)	S	STERILE-SEAL			MOBILE-SEAL	
				4	Hastelloy C* (2.4602)					Code	With existing pipe flanges
				5	Titanium* (3.7035)					W-T	MOBILE-SEAL Wafer
										L-T	MOBILE-SEAL Lug
										W-TW	Mobile Seal Drilling according to DIN 28459

Examples	1	2	3	4	5	6	
GAR-SEAL, WAFER Design	1	1	1	-	-	W	MT
SAFETY-SEAL, LUG Design	3	1	1	A	-	L	MT
MOBILE-SEAL, WAFER Design, acc. to TW Standard	1	1	1	-	-	W-TW	MT
STERILE-SEAL, LUG Design, antistatic	3	1	3	S	-	L	
SAFETY-SEAL, WAFER Design, antistatic	2	1	1	A	-	W	MT
GAR-SEAL, WAFER Design vacuum lining	1	1	1	-	V	W	MT

Performance Data
 DN 50 - 600, 2" - 24"
 Nominal Pressure
 max. 16 bar (< DN 300)
 Vacuum
 up to 1 mbar abs.
 (depending upon temperature)
 Operating temperature
 -40 °C to +200 °C (for PTFE**)
 -40 °C to +85 °C (for UHMWPE***)
 MT = GAR-SEAL Butterfly Valves
 comply with the TA-Luft regulations.

* upon request
 ** Polytetrafluorethylene
 *** Ultrahighmoleculare Polyethylene

All information and recommendations contained in this catalogue are based on many years of experience and the current state of technology. Unknown factors may, however, limit generally accepted knowledge. Binding statements regarding the compatibility of our products are therefore possible only after practical onsite tests under operating conditions. Information contained in our catalogue does therefore not constitute or imply any representation of warranty. While the utmost care has been used in compiling this catalogue, we assume no responsibility for errors. Specifications subject to change without notice. This edition cancels all previous issues. Subject to change without notice.

Applications

GAR-SEAL

GAR-SEAL butterfly valves are used where corrosive, abrasive and toxic media need to be controlled. GAR-SEAL valves are used for controlling, throttling and shutting off purposes in the chemical, petrochemical and chlorine industry as well as in electroplating, the paper industry and many other industries.



Dimensions

- » DN 50 / 2" up to DN 600 / 24"

Flange connection

- » EN 1092 PN 10/16 (Design A/B)
- » ASME B16.5 class 150 lbs (design RF/FF)

Face-to-face dimensions

- » DIN EN 558-1 GR 20
- » ISO 5752 Table 5 short
- » ASME B16.10 (2" to 12" Table Narrow 14" to 24" Table Wide)
- » MSS-SP 67 (2" to 12" Table Narrow 14" to 24" Table Wide)
- » API 609 (2" to 12" Category A 14" to 24" Category B)

Body strength

- » DIN/ EN 12516 T2 (DIN 3840)
- » tested within the scope of the inspection body designate by Module H1

Operating pressure

- » DN 50/2" - 300/12" 16 bar
- » above DN 300/12" 10 bar (depending on operating temperature)

Testing

- » EN 12266 P10
- » EN 12266 P11
- » EN 12266 P12 Leak rate A

Bodies

- » Wafer and Lug design with long neck for insulation

Vacuum

- » up to 1 mbar abs. (depending on size and temperature)

Temperature range

- » -40 °C up to +200 °C
- » -40 °F up to +392 °F (depending on material)

Head flange

- » EN ISO 5211
- » NF E 29-402

Liner

- » PTFE
- » Abrasive PTFE
- » UHMWPE

Applications

SAFETY-SEAL

SAFETY-SEAL valves are used in applications where corrosive, abrasive and toxic media need to be insulated against electrostatic charges.

SAFETY-SEAL valves offer long life and reduced maintenance effort and extra safety.



Dimensions

- » DN 50 / 2" up to DN 600 / 24"

Flange connection

- » EN 1092 PN 10/16 (Design A/B)
- » ASME B16.5 class 150 lbs (design RF/FF)

Face-to-face dimensions

- » DIN EN 558-1 GR 20
- » ISO 5752 Table 5 short
- » ASME B16.10 (2" to 12" Table Narrow 14" to 24" Table Wide)
- » MSS-SP 67 (2" to 12" Table Narrow 14" to 24" Table Wide)
- » API 609 (2" to 12" Category A 14" to 24" Category B)

Body strength

- » DIN/ EN 12516 T2 (DIN 3840)
- » tested within the scope of the inspection body designate by Module H1

Operating pressure

- » DN 50/2" - 300/12" 16 bar
- » above DN 300/12" 10 bar (depending on operating temperature)

Testing

- » EN 12266 P10
- » EN 12266 P11
- » EN 12266 P12 Leak rate A

Bodies

- » Wafer and Lug design with long neck for insulation

Vacuum

- » up to 1 mbar abs. (depending on size and temperature)

Temperature range

- » -40 °C up to +200 °C
- » -40 °F up to +392 °F (depending on material)

Head flange

- » EN ISO 5211
- » NF E 29-402

Liner

- » Antistatic PTFE

Applications

MOBILE-SEAL

MOBILE-SEAL valves are used on road tanker vehicles, railway wagons, silos and other transportation and storage containers where high chemical resistance, reliability and special safety requirements are essential.



Dimensions

- » DN 50 / 2" up to DN 100 / 4"

Flange connection

- » EN 1092 PN 10/16 (Design A/B)
- » ASME B16.5 class 150 lbs (design RF/FF)
- » DIN 28459 PN10

Face-to-face dimensions

- » DIN EN 558-1 GR 20
- » ISO 5752 Table 5 short
- » ASME B16.10 (2" to 4" Table Narrow)
- » MSS-SP 67 (2" to 4" Table Narrow)
- » API 609 (2" to 14" Category A)

Body strength

- » DIN/ EN 12516 T2 (DIN 3840)
- » tested within the scope of the inspection body designate by Module H1

Operating pressure

- » DN 50/2" - 100/4" 10 bar (depending on operating temperature)

Testing

- » EN 12266 P10
- » EN 12266 P11
- » EN 12266 P12 Leak rate A

Bodies

- » Wafer and Lug design with long neck for insulation

Vacuum

- » up to 1 mbar abs. (depending on size and temperature)

Temperature range

- » -40 °C up to +200 °C
- » -40 °F up to +392 °F (depending on material)

Head flange

- » EN ISO 5211
- » NF E 29-402

Certification

- » EN 14432 and TÜ-AGG 044-84

Liner

- » PTFE
- » Antistatic PTFE
- » Abrasive PTFE

Materials

GAR-SEAL, SAFETY-SEAL, MOBILE-SEAL

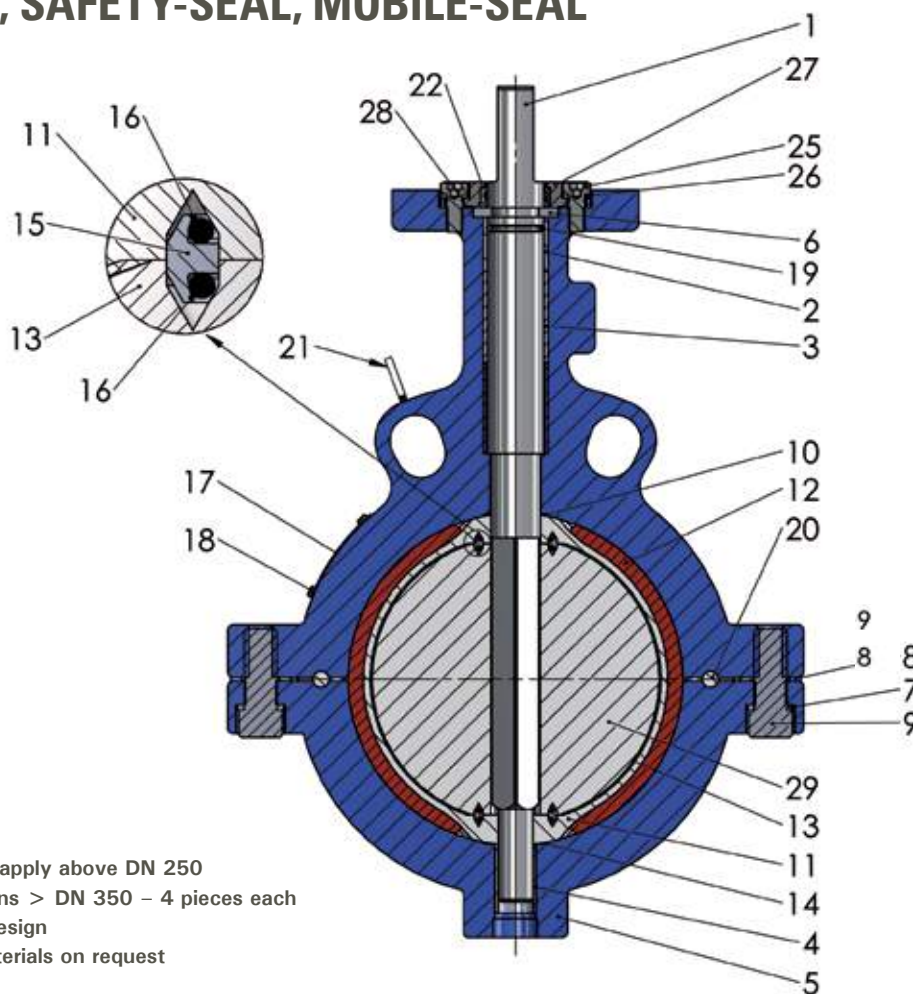

- ¹ does not apply above DN 250
- ² Dimensions > DN 350 – 4 pieces each
- ³ Special design
- ⁴ other materials on request

Pos.	Qty.	Material	Designation	Pos.	Qty.	Material	Designation
1	1	1.4313 up to DN 300 1.4021 up to DN 350	Shaft	15	2	PTFE	Sealring
				16	4 ⁴	Viton	O-Ring (sealring)
2	1	Steel/PTFE	Slide bearing (top)	17	1	Stainless steel	Nameplate
3	2	Steel/PTFE	Slide bearing (center)	18	4	Stainless steel	Rivet
4	1	Steel/PTFE	Slide bearing (bottom)	19	1 ⁴	Viton	O-Ring
5	1	see material table	Body	20	2	PTFE	Security element
6	1 ¹	PTFE, carbon reinf.	Retaining ring (split)	21	1 ³	Steel electroplated	Ground connection
7	2 ²	Stainless steel	Spring washer	22	2 ⁴	Viton	O-Ring (adapter flange)
8	2 ²	GYLON®	Washer				
9	2 ²	Stainless steel	Body screw				
10	1	GYLON®	Top gasket	25	4	Stainless steel	Screw
11	1	see material table	Lining	26	4	Stainless steel	Spring washer
12	2 ⁴	Silicone	Elastomer backup-element	27	1	Stainless steel	Adapter flange
13	1	see material table	Disc	28	1	GYLON®	Seal (adapter flange)
14	1	GYLON®	Bottom gasket	29	1	0.7040 (GGG 40)	Disc insert (only PTFE and UHMWPE lined disc)

Dimensions, Wafer

GAR-SEAL, SAFETY-SEAL, MOBILE-SEAL

Flange connection: EN 1092 (DIN 2501), PN 10 • PN 16 • ANSI B 16.5, 150 LBS
 Overall length: EN 558-1 GR20 (DIN 3202 T3 K1) and ASME B16.10
 Adapter flange: EN ISO 5211

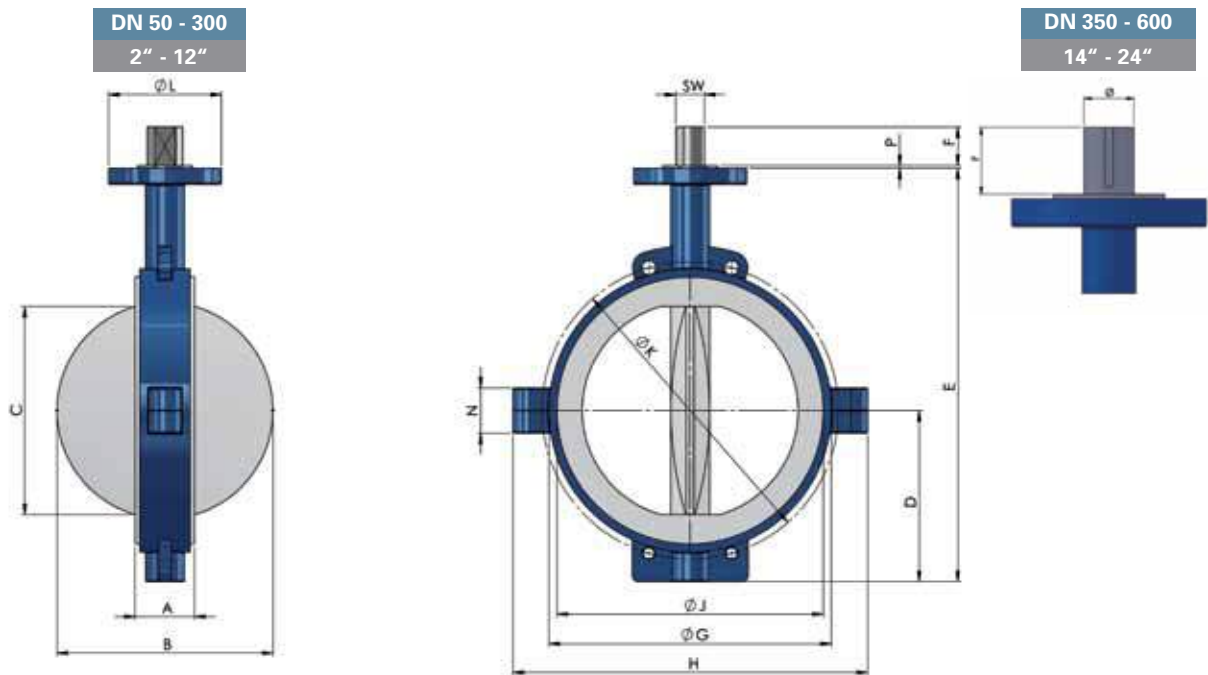

DN		Ad- apter flange **	A	B	C	D	E	F	G	H	J	EN PN10	K ASME 150lbs	L	SW Ø	P	N	EN PN 10	Z ASME 150 lbs	Weight kg
Inch	mm																			
2	50	F05	43	60	43	62	202	35	102	152	98	125	121	65	10,0	3	40	4xM16	4x ⁵ / ₈ "-11	2.60
2 ½	65	F05	46	70	53	70	220	35	121	171	120	145	140	65	10,0	3	40	4xM16	4x ⁵ / ₈ "-11	3.60
3	80	F05	46	82	67	79	244	35	133	183	127	160	152	65	10,0	3	40	8xM16	4x ⁵ / ₈ "-11	4.00
4	100	F07	52	106	93	95	275	35	162	214	159	180	190	90	13,0	3	50	8xM16	8x ⁵ / ₈ "-11	6.10
5	125	F07	56	128	115	108	303	35	192	248	187	210	216	90	13,0	3	50	8xM16	8x ³ / ₄ "-10	8.60
6	150	F10	56	157	147	121	336	40	218	290	216	240	241	125	17,0	3	56	8xM20	8x ³ / ₄ "-10	11.20
8	200	F10	60	197	188	150	395	40	273	350	270	295	298	125	17,0	3	56	8xM20	8x ³ / ₄ "-10	16.40
10	250	F12	68	246	236	179	459	50	328	405	324	350	362	150	22,0	3	60	12xM20	12x ⁷ / ₈ "-9	27.20
12	300	F12	78	295	284	216	536	50	378	455	375	400	432	150	22,0	3	70	12xM20	12x ⁷ / ₈ "-9	36.10
14	350	F14	92*	335	322	265	640	60	438	550	413	460	476	175	44,4	4	70	16xM20	12x 1"-8	71.50
16	400	F14	102	387	374	305	725	60	489	570	470	515	540	175	44,4	4	70	16xM24	16x 1"-8	89.20
18	450	F16	114	430	415	320	780	80	539	670	533	565	578	210	44,4	4	70	20xM24	16x1 ¹ / ₈ "-7	125.40
20	500	F16	127	484	467	355	865	80	594	690	584	620	635	210	44,4	4	70	20xM24	20x1 ¹ / ₈ "-7	157.30
24	600	F25	154	578	558	415	990	90	695	820	692	725	749	300	63,5	5	76	20xM27	20x1 ¹ / ₄ "-7	256.20

MOBILE-SEAL
GAR-SEAL + SAFETY-SEAL

		EN PN16		
8	200	295		12xM20
10	250	355		12xM24
12	300	410		12xM24

for PN 16 > DN 150

*GR 25 ** DIN/ISO 5211

Dimensions, Lug

GAR-SEAL, SAFETY-SEAL, MOBILE-SEAL

Flange connection:

EN 1092 (DIN 2501), PN 10 • PN 16 • ANSI B 16.5, 150 LBS

Overall length:

EN 558-1 GR20 (DIN 3202 T3 K1) and ASME B16.10

Adapter flange:

EN ISO 5211

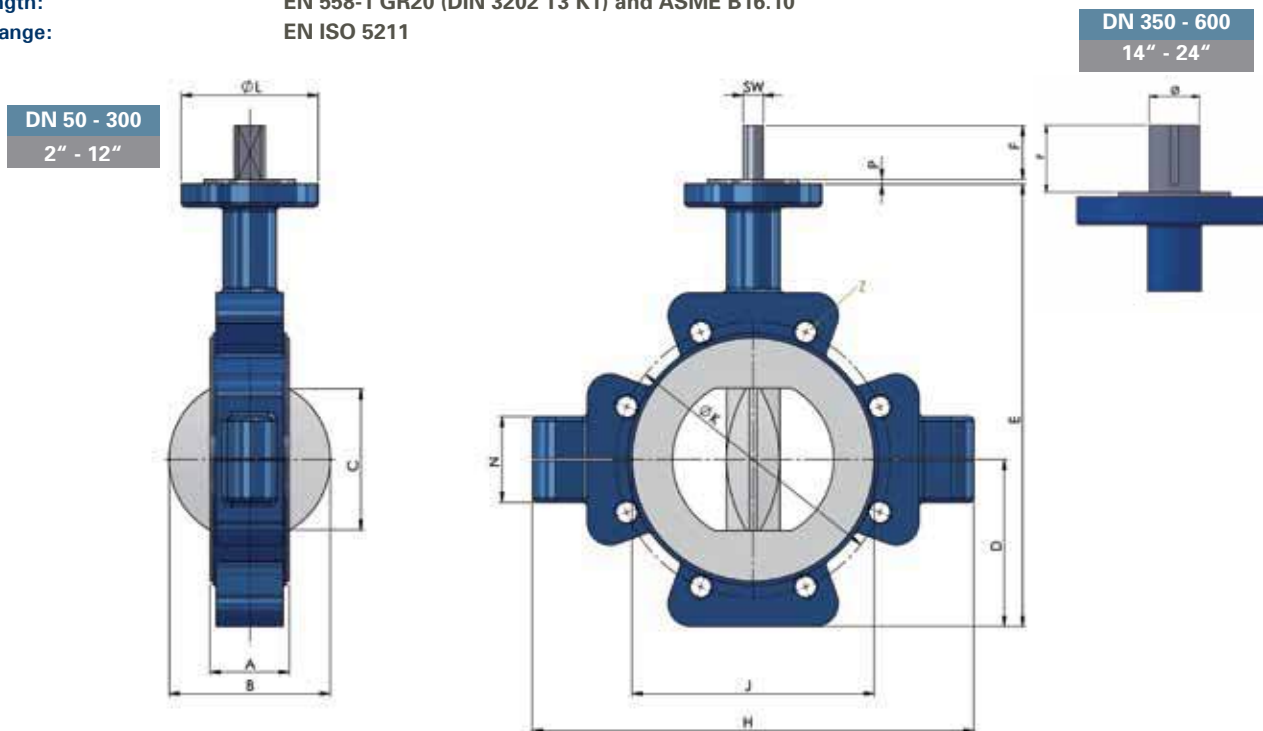

DN	Inch	mm	Ad- apter flange **	A	B	C	D	E	F	H	J	K		L	SW Ø	P	N	Z		Weight kg
												EN PN10	ASME 150lbs					EN PN 10	ASME 150 lbs	
2	2 1/2	50	F05	43	60	43	62	202	35	170	98	125	121	65	10,0	3	45	4xM16	4x5/8"-11	3.40
2 1/2	3	65	F05	46	70	53	70	220	35	193	120	145	140	65	10,0	3	45	4xM16	4x5/8"-11	4.30
3	4	80	F05	46	82	67	91	256	35	252	127	160	152	65	10,0	3	56	8xM16	4x5/8"-11	6.50
4	5	100	F07	52	106	93	109	289	35	290	159	180	190	90	13,0	3	56	8xM16	8x5/8"-11	10.20
5	6	125	F07	56	128	115	120	315	35	312	187	210	216	90	13,0	3	60	8xM16	8x3/4"-10	12.60
6	8	150	F10	56	157	147	136	351	40	312	216	240	241	125	17,0	3	66	8xM20	8x3/4"-10	16.10
8	10	200	F10	60	197	188	163	408	40	416	270	295	298	125	17,0	3	76	8xM20	8x3/4"-10	22.40
10	12	250	F12	68	246	236	200	480	50	508	324	350	362	150	22,0	3	90	12xM20	12x7/8"-9	36.90
12	14	300	F12	78	295	284	233	553	50	575	375	400	432	150	22,0	3	110	12xM20	12x7/8"-9	52.50
14	16	350	F14	92*	335	322	265	640	60	640	413	460	476	175	44,4	4	70	16xM20	12x1"-8	102.50
16	18	400	F14	102	387	374	305	725	60	720	470	515	540	175	44,4	4	70	16xM24	16x1"-8	131.70
18	20	450	F16	114	430	415	320	780	80	750	533	565	578	210	44,4	4	70	20xM24	16x1 1/8"-7	153.90
20	24	500	F16	127	484	467	366	876	80	830	584	620	635	210	44,4	4	70	20xM24	20x1 1/8"-7	247.80
24		600	F25	154	578	558	415	990	90	960	692	725	749	300	63,5	5	76	20xM27	20x1 1/4"-7	385.70

		for PN 16 > DN 150		EN PN16			
8	200			295		12xM20	
10	250			355		12xM24	
12	300			410		12xM24	

*GR 25 ** DIN/ISO 5211

Dimensions, Wafer tank truck

MOBILE-SEAL

Flange connection:

DIN 28459 PN 10

Overall length:

EN 558-1 GR20 (DIN 3202 T3 K1)

Adapter flange:

EN ISO 5211

DN 50 - 65
2" - 12½"

DN 80 - 100
3" - 4"

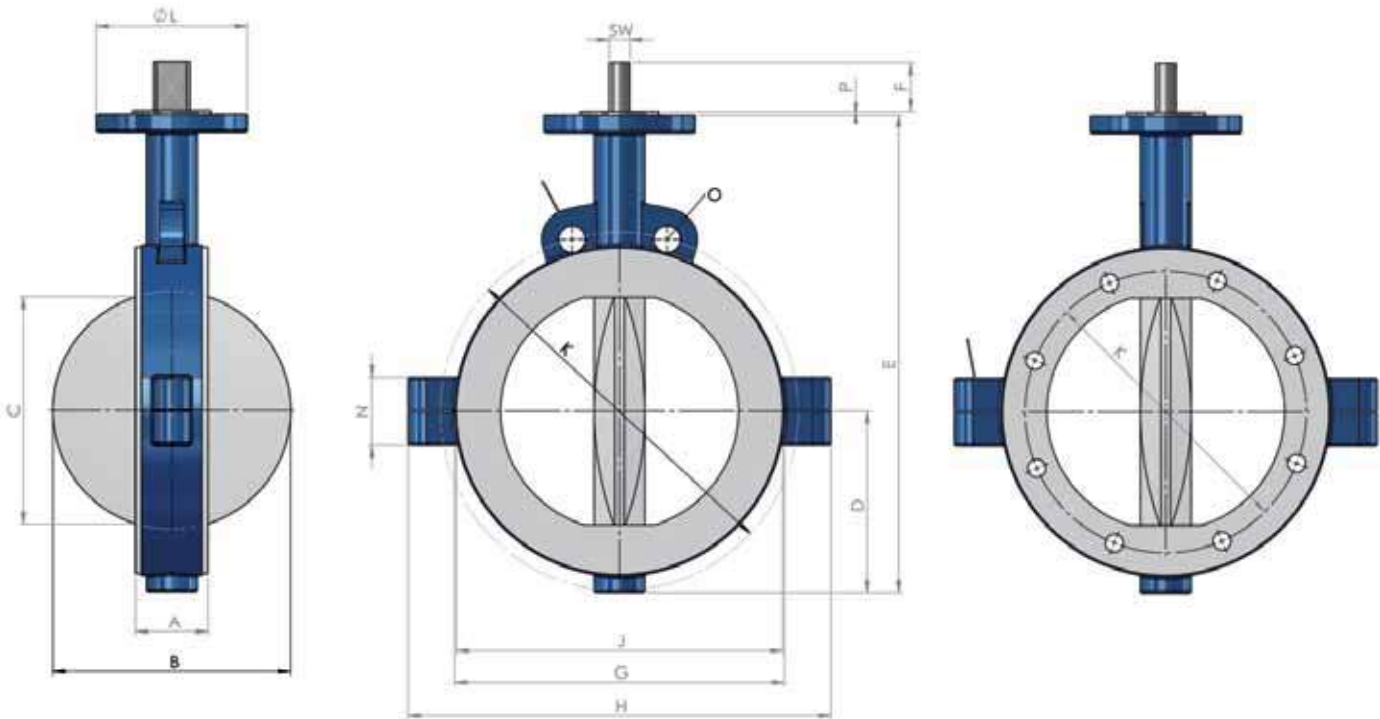

	DN Inch	mm	Adapter flange DIN/ ISO 5211	A	B	C	D	E	F	G	H	J	K	L	SW	P	N	O	Z	Weight kg
MOBILE-SEAL	2	50	F05	43	60	43	62	202	35	102	152	98	130	65	10	3	40	11	8xM10	2.58
	2½	65	F05	46	70	53	70	220	35	121	171	120	130	65	10	3	40	11	8xM10	3.36
	3	80	F05	46	82	67	82	244	35	133	183	127	130	65	10	3	40	11	8xM10	3.68
	4	100	F07	52	106	93	106	275	35	174	217	159	150	90	13	3	40	14	8xM12	6.67

STERILE-SEAL

Applications

STERILE-SEAL valves are used where sterile processes need to be maintained in the pharmaceutical and food industries without unnecessary and costly overhauls and replacement.

The special characteristic of this valve is its external sterilization capability. By the design of the valve the critical „dead“ areas of the valve, as well as the disc, body liner and seals, can be sterilized with steam without contact to the process.



Dimensions

- » DN 50 / 2" up to DN 400 / 16"

Flange connection

- » EN 1092 PN 10/16 (Design A/B)
- » ASME B16.5 class 150 lbs (design RF/FF)

Face-to-face dimensions

- » DIN EN 558-1 GR 20
- » ISO 5752 Table 5 short
- » ASME B16.10 (2" to 12" Table Narrow, 14" to 24" Table Wide)
- » MSS-SP 67 (2" to 12" Table Narrow, 14" to 24" Table Wide)
- » API 609 (2" to 12" Category A, 14" to 24" Category B)

Body strength

- » DIN/ EN 12516 T2 (DIN 3840)
- » tested within the scope of the inspection body designate by Module H1

Operating pressure

- » DN 50/2" - 400/16" 10 bar (depending on operating temperature)

Testing

- » EN 12266 P10
- » EN 12266 P11
- » EN 12266 P12 Leak rate A

Bodies

- » Wafer and Lug design with long neck for insulation

Vacuum

- » up to 1 mbar abs. (depending on operating temperature)

Temperature range

- » -40 °C up to +170 °C
- » -40 °F up to +338 °F (depending on material)

Head flange

- » EN ISO 5211
- » NF E 29-402

Liner

- » PTFE

STERILE-SEAL

No survival for bacteria

For fermentation, sterile processing is the premise to guarantee the optimum productivity of the used microorganisms. All bacteria have to be destroyed before fermentation and also all products fed into the process have to be sterilized. Most important is the avoidance of any contamination during fermentation up to the separation of the biomass and treatment of the final product.

The new re-designed STERILE-SEAL valve with its steam blocking chambers surround and protect the product area against external pollution, even under vacuum conditions. This design is a major breakthrough for large scale biotechnology plants. With the STERILE-SEAL valve bacteria contamination is a thing of the past.

Construction

The media in the inner chamber is protected against contamination by the surrounding isolation chambers which are directly connected to the inner sealing system. A second outer sealing system separates the process from the atmosphere. STERILE-SEAL valves are completely void and cavity-free to prevent any build-up of nutrients.

Operation Principle

Pressurised steam is fed into the steam inlet and distributed through the longitudinal channels of the shaft and out through the flow control at the bottom of the valve body. It is also possible to seal the valve by pressuring the isolation chambers and closing the steam outlet connection.

Sterilization Proof

During tests, STERILE-SEAL valves were contaminated at several points with *Bacillus Stearothermophilus* with a population of $5,7 \times 10^5$. Pressurised steam was then allowed to flow through the two chambers, followed by sterile air. In every instance the bacillus was completely destroyed.

The safe concept

STERILE-SEAL valves meet the highest standards of Garlock's excellence.

For example:

Body

Split-body, manufactured from ductile iron, cast steel or stainless steel. Safety sealing between the two body halves, seals are fitted within the body liner to prevent atmospheric contamination and the escape of media.

Body liner manufactured from high density PTFE*
FDA approved Void-free, impermeable,
liner thickness 3 mm minimum.

Stainless steel disc

For highest demands, i.e. pyrogenic resistant, particle and fibrous free surfaces with max. 1 % delta-ferrite, content:
Forged (WN 1.4435 and others).
Surface finishes to 0,1 μm Ra are available.

Shaft

One-piece manufactured from stainless steel with ring and longitudinal channels. The STERILE-SEAL concept improves the profitability of production processes in pharmaceutical, food and biotechnology industries.

Advantages

- » Safety against contamination
- » Safety against corrosion
- » Safety of the body against over-pressurisation
- » Safety by standardization
- » Safety against leakages
- » Safety by identification

Garlock Butterfly Valves: Trusted throughout chemical, petrochemical and many other industries

STERILE-SEAL

2-chamber-system guarantees production safety

PTFE*, isostatically molded. High density, high crystallinity, stainless steel discs. STERILE-SEAL valves are available in wafer and lug design in all sizes from 2" (DN 50) to 16" (DN 400). Actuators of any kind and type can be mounted.

Service pressure:

from vacuum up to 10 bar

Service temperature:

-40 °C to +170 °C (200 °C**), 40 °F to 338 °F (392 °F**)

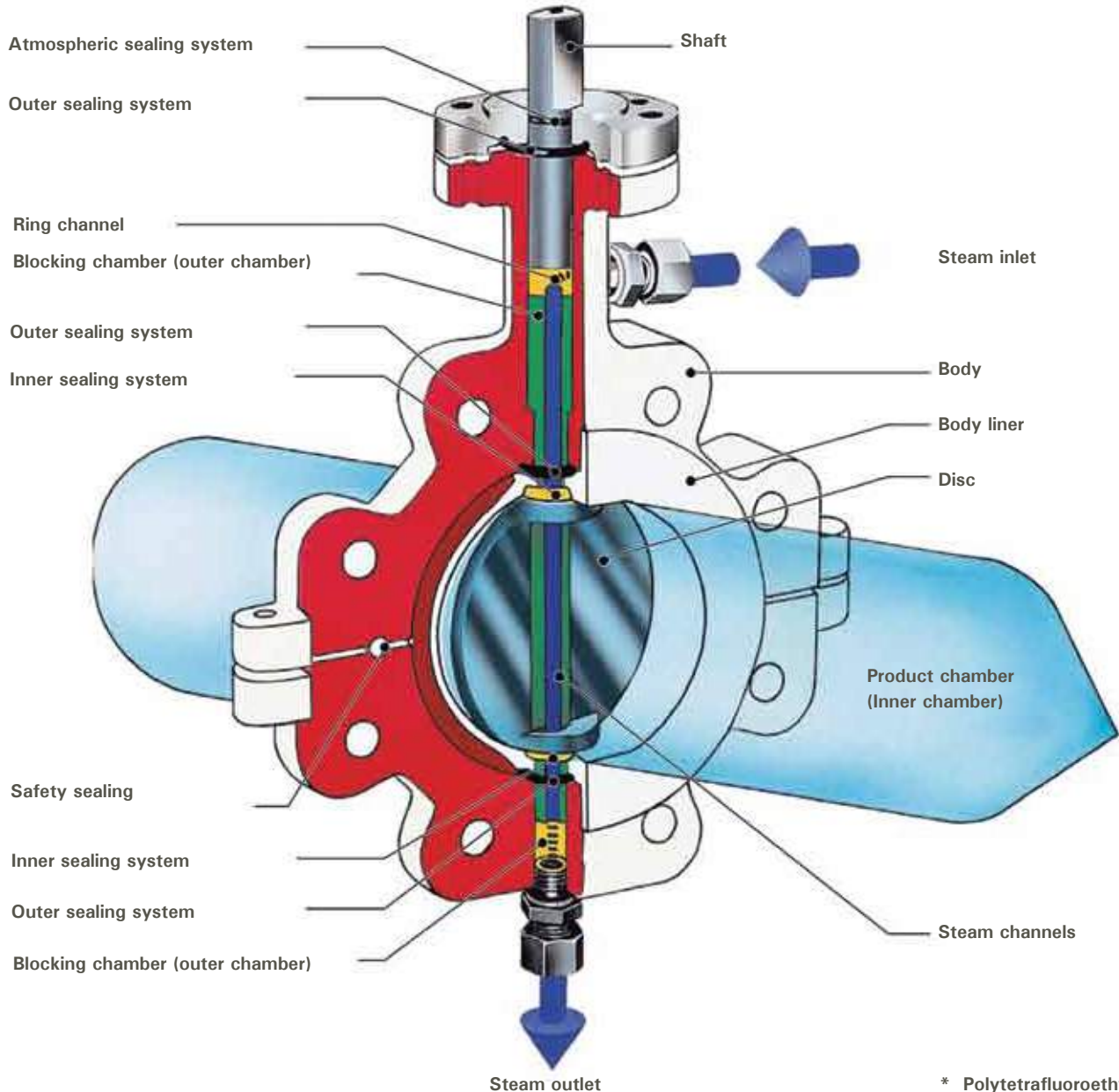

* Polytetrafluoroethylene
 ** Please ask Garlock

Dimensions

STERILE-SEAL

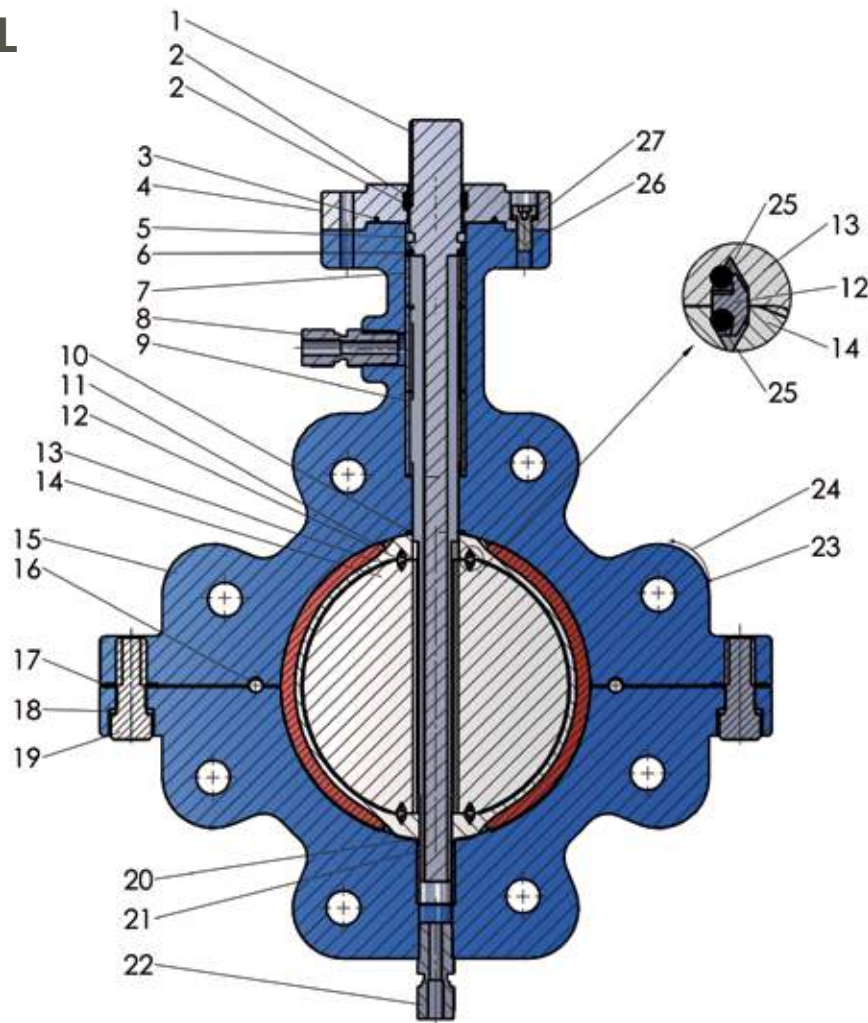

Pos.	Qty.	Material	Designation	Pos.	Qty.	Material	Designation
1	1	1.4313 up to DN 300 1.4021 from DN 350	Shaft	15	1	s. table	Body
2	2 ⁴	EPDM	O-Ring (shaft)	16	2	PTFE	Security element
3	1 ⁴	EPDM	O-Ring (top flange)	17	2	PTFE	washer
4	1	1.4301	Top flange	18	2	Stainless steel	Spring washer
5	1	PTFE, carbon reinf.	retaining ring (split)	19	2	Stainless steel	Body screw
6	1 ⁴	EPDM	O-Ring (shaft)	20	1 ⁴	EPDM	O-Ring (liner)
7	1	Steel/PTFE	slide bearing (top)	21	1	Steel/PTFE	slide bearing (bottom)
8	1	GYLON	Fitting	22	1	Stainless steel	Fitting
9	2	Stainless steel	slide bearing (center)	23	4	Stainless steel	Groove pin
10	1 ⁴	EPDM	O-Ring (liner)	24	1	Stainless steel	Nameplate
11	2 ⁴	EPDM	Elastomer backup element	25	4 ⁴	EPDM	O-Ring (sealing)
12	2	PTFE	Sealing	26	4	Stainless steel	Locking screw
13	1	see material table	Liner	27	4	Stainless steel	Spring washer
14	1	see material table	Valve disc				

¹ does not apply above DN 250

² > DN 350 – 4 Pc. each

³ Special design

⁴ other materials on request

Dimension, Wafer

STERILE-SEAL

Flange connection:

EN 1092 (DIN 2501), PN 10 • PN 16 • ANSI B 16.5, 150 LBS

Overall length:

EN 558-1 GR20 (DIN 3202 T3 K1)

Adapter flange:

EN ISO 5211

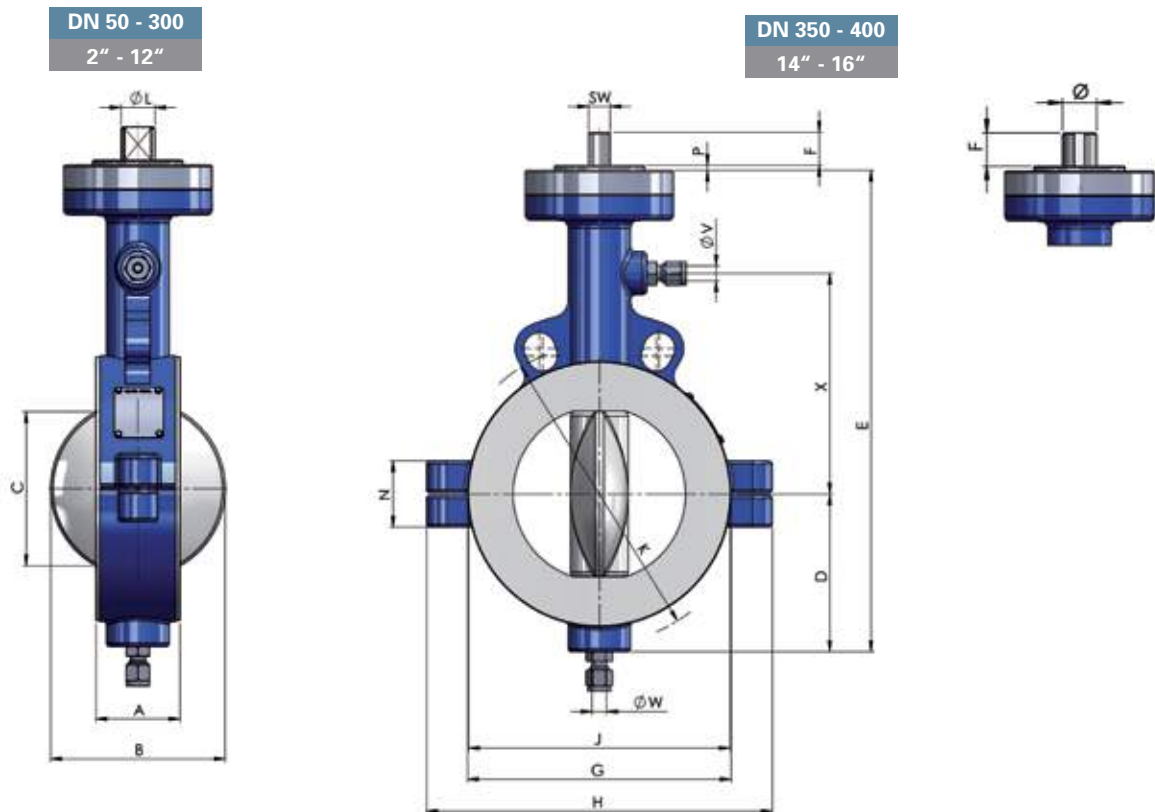

DN Inch	DN mm	Ad- apter flange **	A	B	C	D	E	F	G	H	J	K EN PN10	K ASME 150lbs	L	SW Ø	P	N	ØV	ØW	EN PN10	ASME 150 lbs	X	Weight kg
2	50	F05	43	60	43	62	214	35	102	152	98	125	121	65	10,0	3	40	10	10	4xM16	4x ^{5/8} -11	103	3.00
2 ½	65	F05	46	70	53	70	232	35	121	181	120	145	140	65	10,0	3	40	12	12	4xM16	4x ^{5/8} -11	113	4.10
3	80	F05	46	82	67	79	256	35	133	183	127	160	152	65	10,0	3	40	12	12	8xM16	4x ^{5/8} -11	128	4.50
4	100	F07	52	106	93	95	290	35	162	214	159	180	190	90	13,0	3	50	12	12	8xM16	8x ^{5/8} -11	133	7.00
5	125	F07	56	128	115	108	318	35	192	248	187	210	216	90	13,0	3	50	12	12	8xM16	8x ^{3/4} -10	148	9.50
6	150	F10	56	157	147	121	351	40	218	290	216	240	241	125	17,0	3	56	12	12	8xM20	8x ^{3/4} -10	168	12.90
8	200	F10	60	197	188	150	410	40	273	350	270	295	298	125	17,0	3	56	12	12	8xM20	8x ^{3/4} -10	198	18.10
10	250	F12	68	246	236	179	474	50	328	405	324	350	362	150	22,0	3	60	18	18	12xM20	12x ^{7/8} -9	228	29.70
12	300	F12	78	295	284	216	551	50	378	455	375	400	432	150	22,0	3	70	18	18	12xM20	12x ^{7/8} -9	258	38.60
14	350	F14	92*	335	322	265	670	60	438	550	413	460	476	175	44,4	4	70	25	25	16xM20	12x1"-8	314	77.20
16	400	F14	102	387	374	305	755	60	489	570	470	515	540	175	44,4	4	70	25	25	16xM24	16x1"-8	359	94.90

8	200	for PN 16 > DN 150										295		12xM20	
10	250											355		12xM24	
12	300											410		12xM24	

*GR 25 ** DIN/ISO 5211

Dimension, Lug

STERILE-SEAL

Flange connection:

EN 1092 (DIN 2501), PN 10 • PN 16 • ANSI B 16.5, 150 LBS

Overall length:

EN 558-1 GR20 (DIN 3202 T3 K1)

Adapter flange:

EN ISO 5211

2" to 24" • DN 50 to DN 600

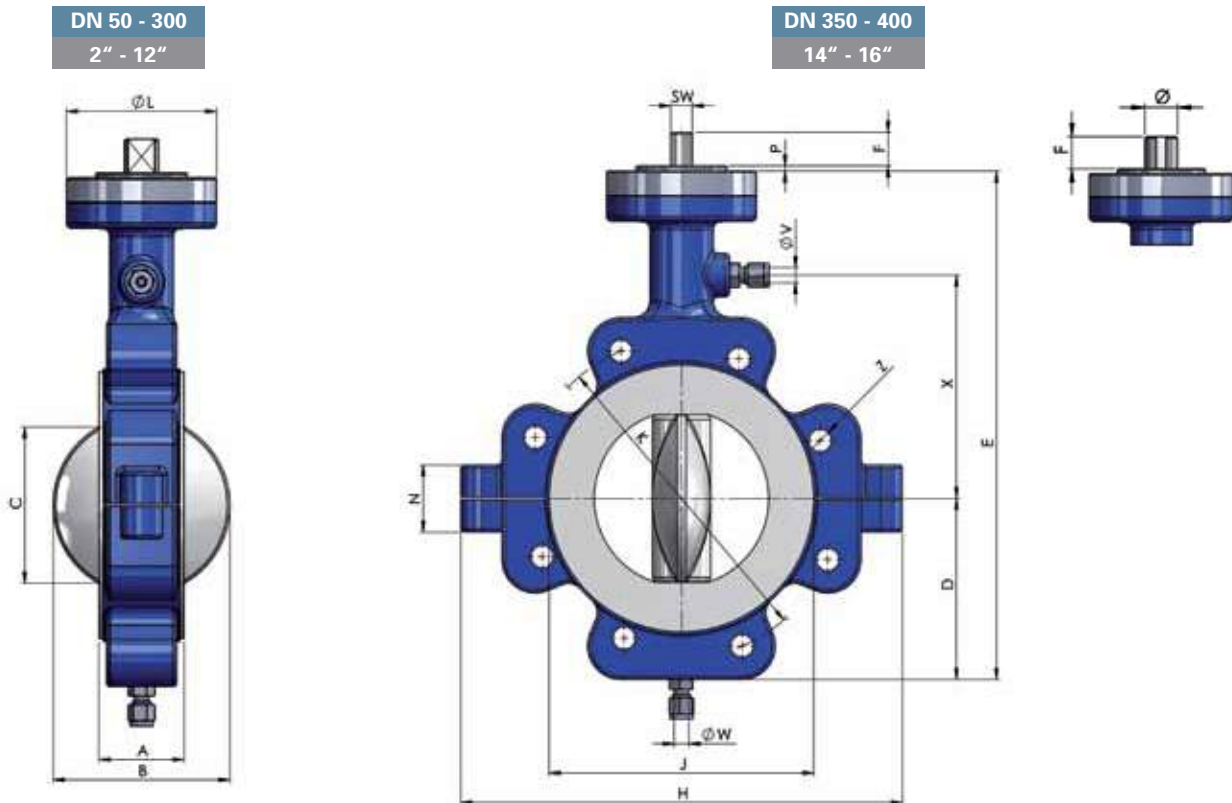

NPS Inch	DN mm	Ad- apter flange **	A	B	C	D	E	F	H	J	K EN PN10	K ASME 150lbs	L	SW Ø	P	N	ØV	ØW	EN PN10	ASME 150 lbs	X	Weight kg
2	50	F05	43	60	43	62	214	35	170	98	125	121	65	10,0	3	45	10	10	4xM16	4x ^{5/8} -11	103	3,80
2 ½	65	F05	46	70	53	70	232	35	193	120	145	140	65	10,0	3	45	12	12	4xM16	4x ^{5/8} -11	113	4,80
3	80	F05	46	82	67	79	256	35	252	193	160	152	65	10,0	3	56	12	12	8xM16	4x ^{5/8} -11	128	7,0
4	100	F07	52	106	93	95	290	35	290	252	180	190	90	13,0	3	56	12	12	8xM16	8x ^{5/8} -11	133	11,1
5	125	F07	56	128	115	108	318	35	312	187	210	216	90	13,0	3	60	12	12	8xM16	8x ^{3/4} -10	148	13,5
6	150	F10	56	157	147	121	351	40	362	216	240	241	125	17,0	3	66	12	12	8xM20	8x ^{3/4} -10	168	17,8
8	200	F10	60	197	188	150	410	40	416	270	295	298	125	17,0	3	76	12	12	8xM20	8x ^{3/4} -10	198	24,10
10	250	F12	68	246	236	179	474	50	508	324	350	362	150	22,0	3	90	18	18	12xM20	12x ^{7/8} -9	228	39,40
12	300	F12	78	295	284	234	551	50	575	375	400	432	150	22,0	3	110	18	18	12xM20	12x ^{7/8} -9	258	55,0
14	350	F14	92*	335	322	265	670	60	640	413	460	476	175	44,4	4	70	25	25	16xM20	12x1"-8	314	108,20
16	400	F14	102	387	374	305	755	60	720	470	515	540	175	44,4	4	79	25	25	16xM24	16x1"-8	359	137,40

8	200	for PN 16 > DN 150	295		12xM20	
10	250		355		12xM24	
12	300		410		12xM24	

*GR 25 ** DIN/ISO 5211

Explosion View

STERILE-SEAL

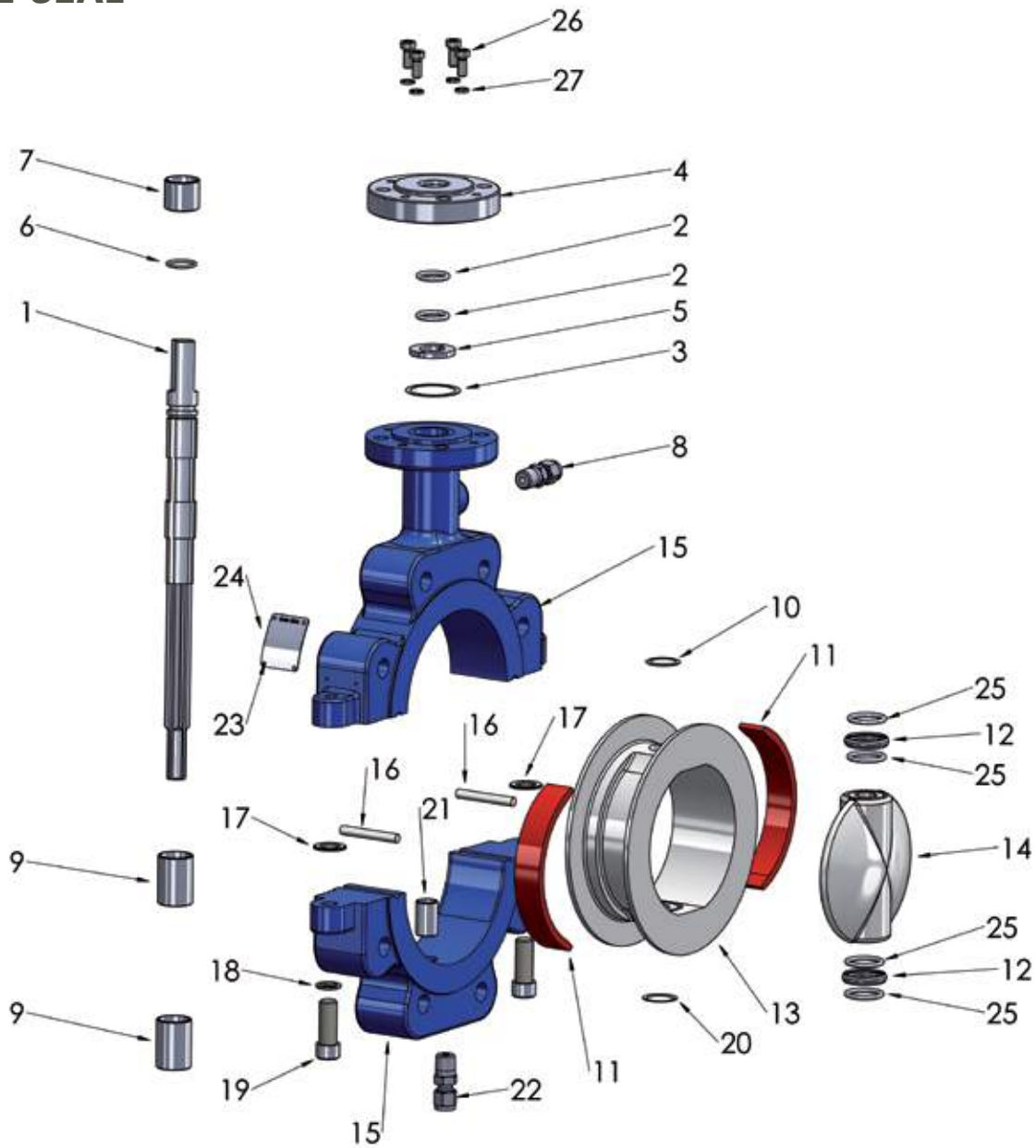

Pos.	Designation	Pos.	Designation	Pos.	Designation	Pos.	Designation
1	Shaft	8	Fitting	15	Body	22	Fitting
2	O-Ring (shaft)	9	Slide bearing (center)	16	Security element	23	Groove pin
3	O-Ring (top flange)	10	O-Ring (liner)	17	Washer	24	Name plate
4	Top flange	11	Elastomere back-up	18	Spring washer	25	O-Ring (sealing)
5	Retaining ring (split)	12	Seal ring	19	Body screw	26	Locking screw
6	O-Ring (shaft)	13	Liner	20	O-ring (liner)	27	Spring washer
7	Slide bearing (top)	14	Disc	21	Slide bearing (bottom)		

* Special Design

Mounting flange

Lug + Wafer, MOBILE-SEAL, GAR-SEAL, SAFETY-SEAL, STERILE-SEAL

According to ISO 5211

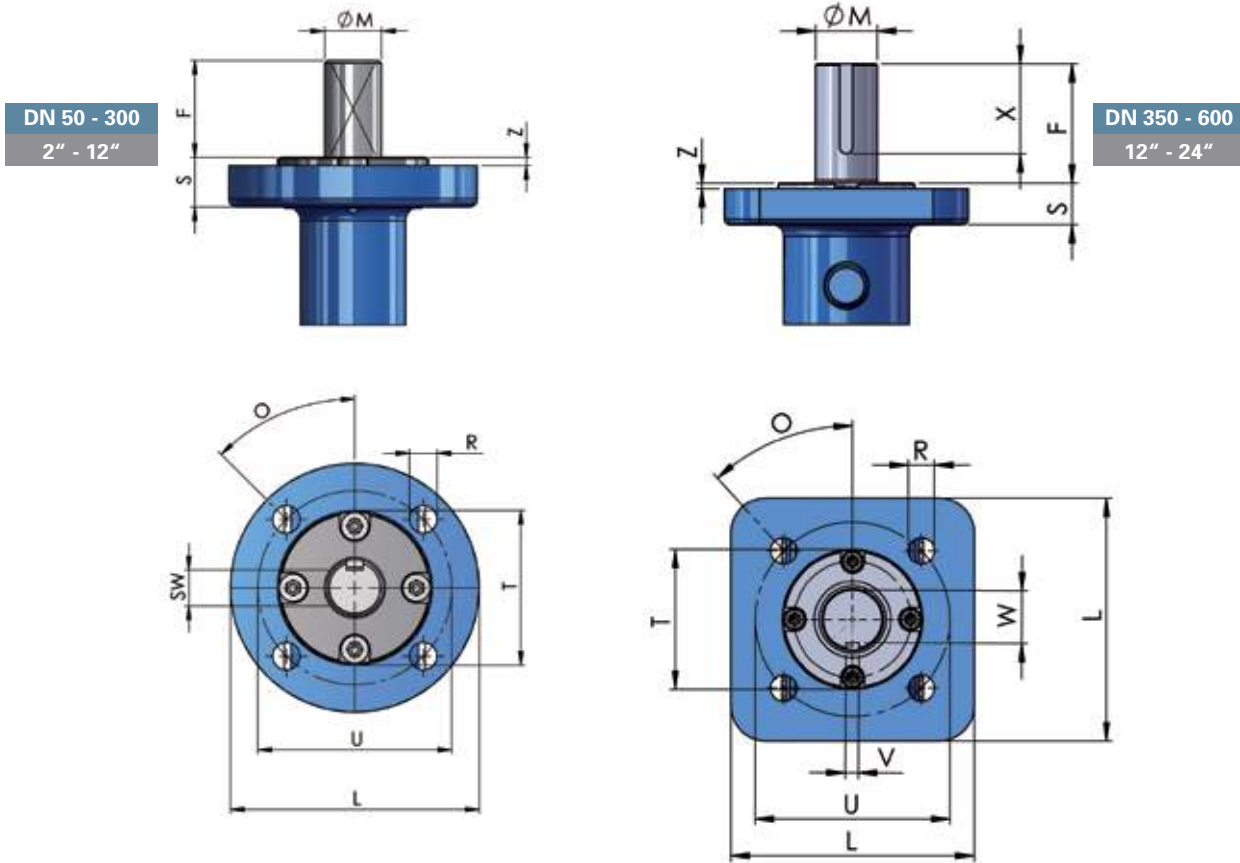

DN		Adapter-flange EN ISO 5211	F	SW	L	Ø M	O	n x R	S*	S**	U	T	Z	V	W	X
Inch	mm															
2/ 2 ½ / 3	50/65/80	F05	35	10	65	14,2	45°	4 x 7	15	27	50	35	3	-	-	-
4/5	100/125	F07	35	13	90	20,5	45°	4 x 9	18	33	70	55	3	-	-	-
6/8	150/200	F10	40	17	125	25,3	45°	4 x 11	18	33	102	70	3	-	-	-
10/12	250/300	F12	50	22	150	32,4	45°	4 x 13	21	36	125	85	3	-	-	-
14/16	350/400	F14	60	-	175	44,4	45°	4 x 17	34	64	140	100	4	9.5	39	55
18/20	450/500	F16	80	-	210	44,4	45°	4x 22	44	-	165	130	4	9.5	39	55
24	600	F25	90	-	300	63,5	22,5°	8 x 17	60	-	254	200	5	16.0	54	70

* GAR-SEAL, SAFETY-SEAL, MOBILE-SEAL

** STERILE-SEAL

Hand-Lever

Lug + Wafer, GAR-SEAL, SAFETY-SEAL, STERILE-SEAL

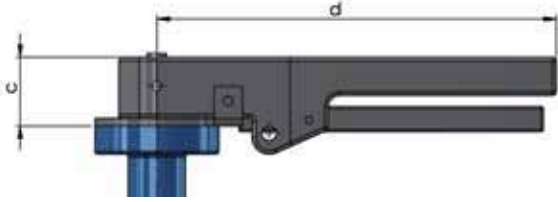

Inch	DN	a	b	c	d	Weight kg
	mm					
2 / 2 ½ / 3	50/65/80	32,5	45	38	210	1
4/5	100/125	45	57	38	300	1.5
6/8	150/200	80	80	43	500	3.5

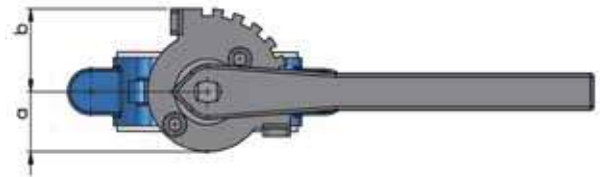

ADR-Hand-Lever

Lug + Wafer, MOBILE-SEAL

ADR Locking handle for hazardous transports

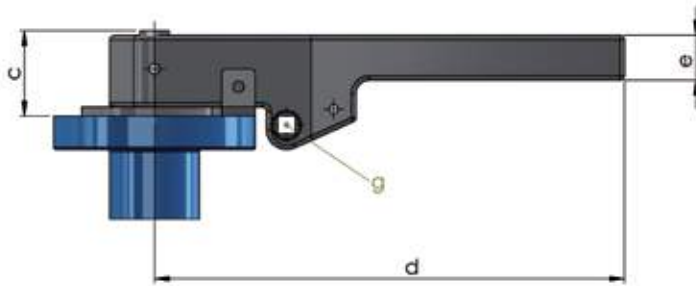

Inch	DN	a	b	c	d	e	f	g	Weight kg
	mm								
2, 2 ½, 3	50, 65, 80	32,5	45	38	210	20	20	8	0,90
4, 5	100, 125	45	57	38	300	20	20	8	1,20
6, 8	150, 200	80	80	43	500	26	26	8	3,10

Gear Operator

Lug + Wafer, GAR-SEAL, SEFETY-SEAL, MOBILE-SEAL, STERILE-SEAL

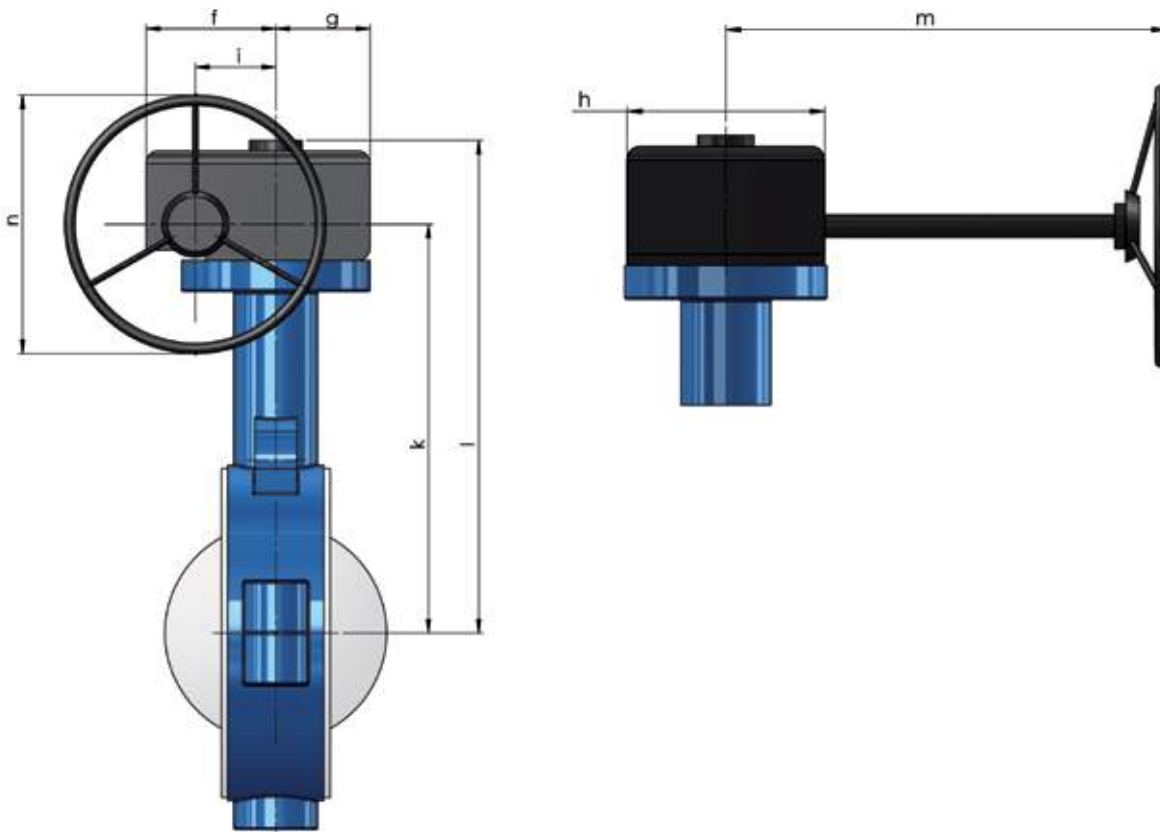

DN	Inch mm	f	g	h	i	k*	l*	k**	l**	m	n	Gross weight (kg)	
												TYP W Wafer	Typ L Lug
2	50	62	45	88	38,5	166,5	198	179,5	210	152	125	6.60	7.40
2 ½	65	62	45	88	38,5	167,5	208	180,5	220	152	125	7.60	8.30
3	80	62	45	88	38,5	191,5	223	203,5	230	152	125	8.00	10.50
4	100	62	45	88	38,5	206,5	238	221,5	253	152	125	10.10	14.20
5	125	62	45	88	38,5	221,5	253	236,5	268	152	125	12.60	16.60
6	150	83,5	58	116	52	250	282	265	297	182	250	18.00	22.90
8	200	83,5	58	116	52	280	312	295	327	182	250	23.20	29.20
10	250	105	75	150	66,7	322	361	337	376	216	300	38.20	47.90
12	300	105	75	150	66,7	362	401	377	416	216	300	47.10	63.50
14	350	131	86	198	89,5	425	468	455	498	283	450	89.00	120.00
16	400	131	86	198	89,5	470	513	500	543	283	450	106.70	149.20
18	450	178	114	252	123	510	566	-	-	335	450	152.40	180.90
20	500	178	114	252	123	560	611	-	-	335	450	184.30	274.80
24	600	209	117	315	154	625	702	-	-	360	450	289.20	427.70

* GAR-SEAL, SAFETY-SEAL, MOBILE-SEAL
** STERILE-SEAL

Technical Data

GAR-SEAL, SEFETY-SEAL, MOBILE-SEAL, STERILE-SEAL

Torques

For selecting the correct valve actuation the values below represent the maximum torques for the opening and closing action.

Flow Rate

For liquids the following references apply:
 Constant control: 4,5 m/s
 Open/Close control: 7,5 m/s

For GAR-SEAL Butterfly Valves with UHMPE^{*1}-Lining the maximum flow rate is limited to 3,5 m/s.

Body lining

		PTFE	PTFE antistatic PTFE abrasive	PTFE Standard vacuum* ²	PTFE antistatic/ PTFE abrasive Standard vacuum* ²	UHMWPE	PTFE Special vacuum* ³
Inch	mm	Nm					
2	50	35	35	35	35	42	not available
2½	65	45	45	45	45	45	
3	80	48	48	48	48	58	
4	100	69	80	83	92	83	
5	125	92	106	111	123	111	
6	150	138	159	166	184	166	
8	200	190	220	230	260	228	280
10	250	320	370	390	430	384	470
12	300	450	520	540	600	540	650
14	350	690	800	900	1040	830	1100
16	400	1040	1200	1360	1560	1250	1650
18	450	1390	1600	1810	2090	1670	2200
20	500	1620	1870	2110	2430	1945	2550
24	600	3460	3990	4500	5690	4150	5500

*1 Ultrahighmolecular polyethylene

*2 Standard-Vacuum:

5 mm Vacuumlining up to DN 300/12"
 7 mm Vacuumlining from
 DN 350 to DN 600/14" to 24"

*3 Special vacuum:

7 mm DN 200-300/ 8"-12"
 10 mm DN 350-600/ 14"-24"

All stated values reflect "net" torques. For the actuator design a safety factor of 10 - 15 % should be taken into consideration.

P x T-Diagram GAR-SEAL Butterfly Valve

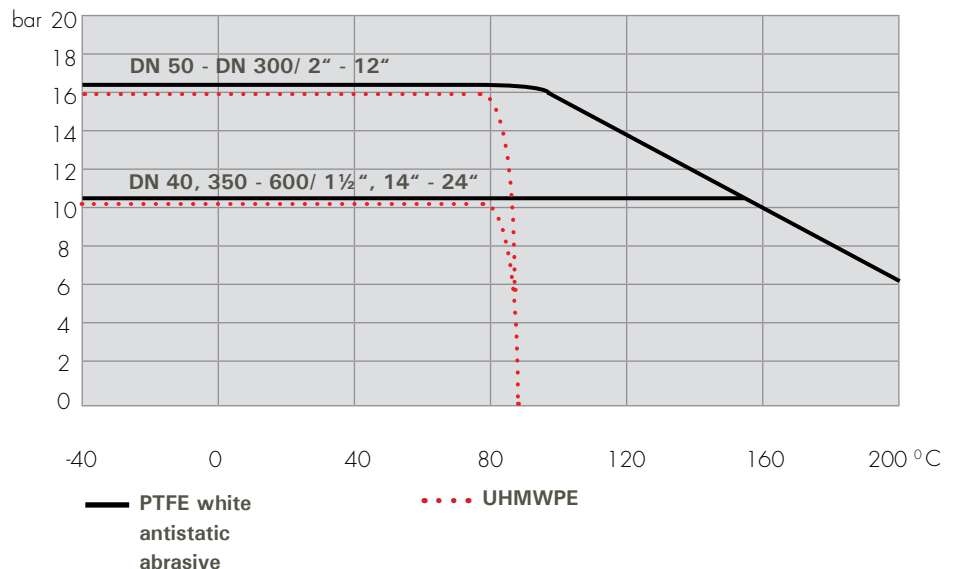

Technical Data

GAR-SEAL, SEFETY-SEAL, MOBILE-SEAL, STERILE-SEAL

Open/Close control – characteristic curve

The graph shows the percentage flow rate, depending upon the disc-aperture. The curve reflects a throttle valve of any size with slight modifications depending upon thickness and profile of the disc itself. Throttle valves with apertures above 60° should be used for on/off control only.

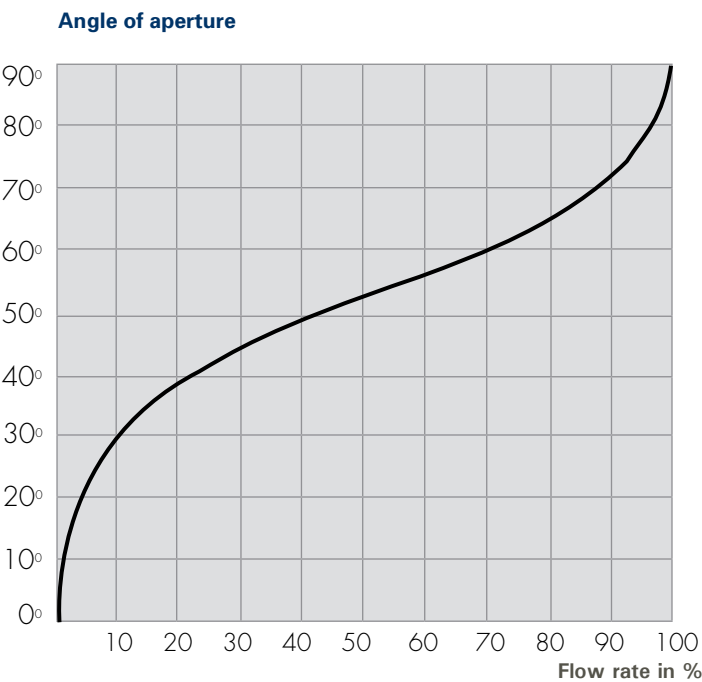

Continuous control / characteristic curve

For continuous control of a throttle valve the flow rate for a 60° aperture is defined with 100 % to provide a flow reserve. The graph has a characteristic of similar percentage for disc opening from 0° to 60°.

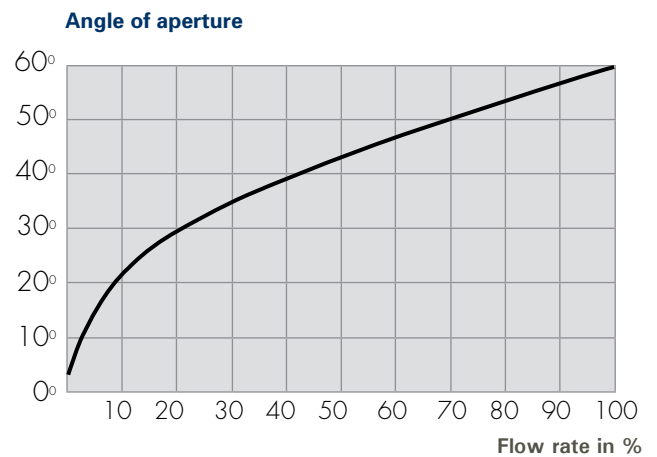

Nominal bore		kv-factor against the angle of aperture							
Inch	mm	20°	30°	40°	50°	60°	70°	80°	90°
2	50	1	13	25	37	54	69	81	84
2 ½	65	2	16	34	52	82	112	130	132
3	80	2	16	38	80	133	191	243	244
4	100	9	43	87	144	228	316	399	420
5	125	16	61	122	210	262	497	670	710
6	150	22	113	215	364	547	822	972	997
8	200	35	165	332	555	874	1215	1534	1613
10	250	65	301	608	1015	1599	2221	2805	2950
12	300	96	446	900	1504	2369	3291	4157	4371
14	350	136	632	1277	2133	3360	4669	5896	6200
16	400	194	898	1813	3027	4770	6626	8369	8800
18	450	237	1097	2215	3698	5824	8095	10223	10750
20	500	297	1377	2781	4644	7317	10166	12839	13500
24	600	420	1948	3935	6570	10352	14382	18164	19100

kv-values against the angle of aperture

The kv-factor reflects the flow of water (density 1 = 1000 kg/m³) in m³/h for a pressure gradient of Δp = 1 bar. The resistance characteristic of the butterfly valve is subject to the kv-factor. It replaces all earlier definitions, see cross-section, flow and friction coefficient. A detailed butterfly valve dimensioning for maximum flow and/or for throttle use is performed by CONVAL-Software programming. Please consult Garlock directly.

Special Vacuum Design

Garlock valves with special vacuum resistant liners

Garlock valves have for decades operated under extreme vacuum conditions.

Past statements on vacuum stress have been made and documented, but only at ambient temperature and the valve closed. This is very ambiguous to a plant engineer. His requirements are the actual vacuum data at all temperatures. Plant vacuum can go down to 1 mbar together with higher temperatures. This often leads to leakages and malfunctions as the liner can be deformed. Garlock has developed special vacuum versions of its GAR-SEAL valves to meet these particular demands.

Vacuum applications of fluorocarbon lined valves with separate liners are subject to special parameters. Therefore not only the actual vacuum is important, but also the service temperature, the thickness of the liner and its geometry.

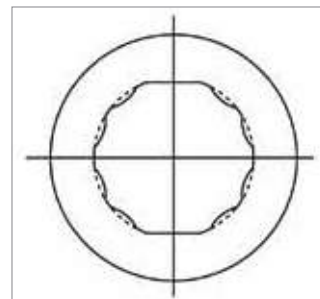

Typical appearance of high vacuum-loaded Body Liner

Garlock with its successful development program and substantial testing of various sizes, including DN 500, at temperatures up to 200 °C concluded that such extreme service conditions can be handled.

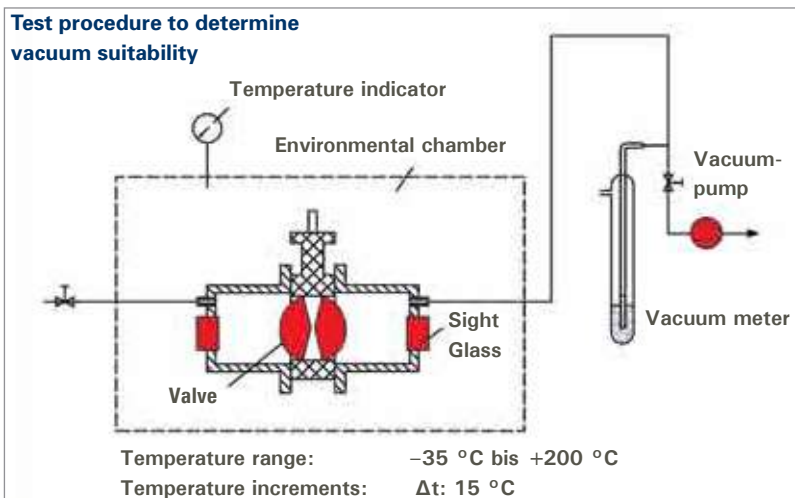

GAR-SEAL Valves can be supplied with varying liner thicknesses for vacuum duties.

The DN 100 size liners show the difference between the standard 3 mm thick and the vacuum 5 mm thick liners. The liner thickness substantially improves the performance against high vacuum stress.

In the DN 100 valve the 3 mm thick liner will operate to 1 mbar, while the 5 mm liner operates below 1 mbar vacuum. Depending on the operating vacuum and temperature and size of valve, the liner thickness can be calculated and selected between 3 mm and 10 mm for GAR-SEAL valves.

Please contact Garlock directly for your specific requirements on vacuum applications.

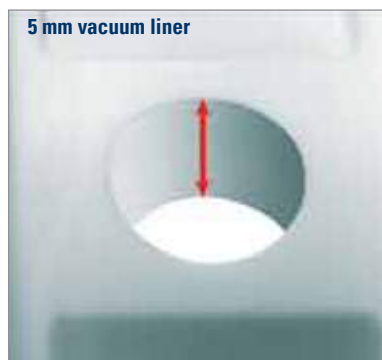

Data and Facts for Vacuum Design

Functionally safe and leak free

Facts and figures for the use with vacuum

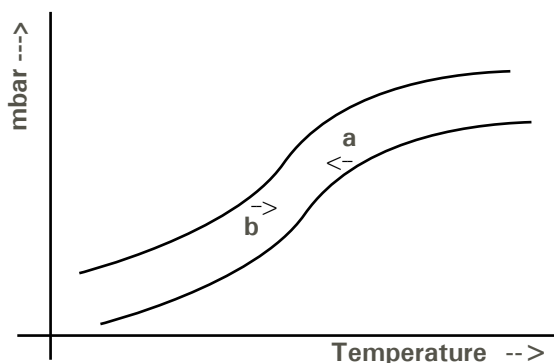

Typical characteristics of body liners under vacuum stress depending on temperature

- a) Increase size and/or decrease liner thickness
 $DN\ 1 > DN\ 2; s_1 < s_2$
- b) Increasing liner thickness and/or higher moment of resistance by altering geometry
 $s_2 > s_1$

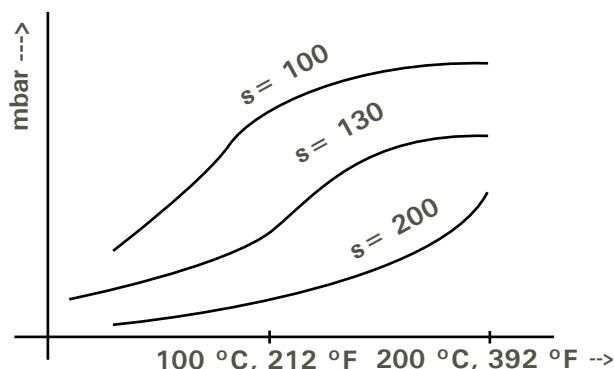

Stress example of Garlock DN 300 body liner with same geometry but different liner thickness "s".

A 30 % increase of the liner thickness at a service temperature of 160 °C improves the vacuum resistance by 35 %. A doubling of the lining thickness will lead to a 85 % increase in the vacuum resistance.

Recommended application limits for GAR-SEAL valves with standard body liners.

For applications in vacuum and/or temperatures above these values special body liners are necessary. Please contact Garlock directly.

DN 50 ≤ DN 150	≤ 100 °C/ 212 °F	5 mbar
	> 100 °C/ 212 °F ≤ 150 °C/ 302 °F	170 mbar
	> 100 °C/ 212 °F ≤ 150 °C/ 302 °F	300 mbar
DN 200 ≤ DN 300	≤ 100 °C/ 212 °F	500 mbar
	> 100 °C/ 212 °F ≤ 150 °C/ 302 °F	560 mbar
	> 100 °C/ 212 °F ≤ 150 °C/ 302 °F	630 mbar
DN 350 ≤ DN 600	≤ 100 °C/ 212 °F	665 mbar
	> 100 °C/ 212 °F ≤ 150 °C/ 302 °F	722 mbar
	> 100 °C/ 212 °F ≤ 150 °C/ 302 °F	770 mbar



All information and recommendations contained in this catalogue are based on many years of experience and the current state of technology. Unknown factors may, however, limit generally accepted knowledge. Binding statements regarding the compatibility of our products are therefore possible only after practical onsite tests under operating conditions. Information contained in our catalogue does therefore not constitute or imply any representation of warranty. While the utmost care has been used in compiling this catalogue, we assume no responsibility for errors. Specifications subject to change without notice. This edition cancels all previous issues. Subject to change without notice.

GARLOCK GMBH

EnPro Industries family of companies

Tel: +49 2131 349 0

Fax: +49 2131 349 222

www.garlock.com

Garlock Sealing Technologies

Garlock Rubber Technologies

GPT

Garlock PTY

Garlock do Brasil

Garlock de Canada, LTD

Garlock China

Garlock Singapore

Garlock USA

Garlock India Private Limited

Garlock de Mexico, S.A. De C.V.

Garlock New Zealand

Garlock Great Britain Limited

Garlock Middle East